

Large Capacity Centrifuges

Component R12 / R6 / wR

- Well recognized model in blood banks and large sample handling laboratories
- Optimized for consistent separation of plasma, buffy coat, RBC, etc.
- Any types of blood bags applicable from 250 mL to 500 mL
- 12 blood bags per run (Component R12), 6 blood bags per run (Component R6)
- Ideal for large number of sample handling (180 vacutainers at a time)
- Windshield rotor to reduce the air resistance and enable to spin over 4,000 rpm
- Dual ramp acceleration and deceleration profile for gentle and quick running
- Ergonomically arranged control and large display with comprehensive information
- Imbalance cutoff and tracking
- Excellent temperature control
- Easy to clean specially coated glossy surface



WS1000-6 / B1000

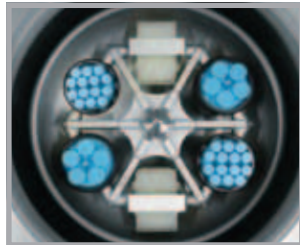

WS750-6 / B750 & TM96

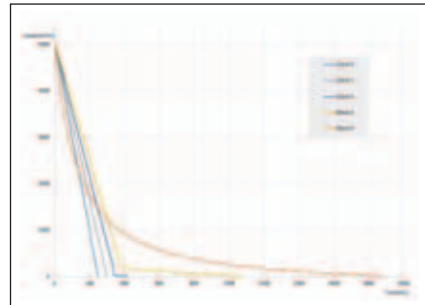

Two-step DEC control at DEC 1~5 and natural slow break at DEC 0



Component R6



Component R12

Large Capacity Centrifuges

Component R12 / Component R6 / Component wR



Component wR

Technical Specifications

		Component R12 / *Component 12R	Component R6 / *Component R	Component wR / *Continent 512R
Speed	Max. RPM / Swing-out	4,800 rpm	5,000 rpm	4,500 rpm
RCF (xg)	Max. RCF / Swing-out	7,470 xg	7,261 xg	5,096 xg
Max. capacity / Swing-out		6 x 2,400 mL	6 x 1,000 mL	6 x 750 mL
ACC/DEC	ACC/DEC ramps	10/10 steps		
	Two step Deceleration	Yes		
Temperature	Temperature range	-10°C to 40°C	-20°C to 40°C	-20°C to 40°C
	Temperature offset	Yes		
Time control		< 100 hr, continuous	< 100 hr, continuous	< 100 hr, pulse, continuous
Program memory		100		
Noise level		≤ 65 dB	≤ 65 dB	≤ 65 dB
Imbalance cutoff / tracking		Yes / Yes	Yes / Yes	Yes / Yes
Rotor identification		Automatic	Automatic	Automatic
Dimension (W x D x H, mm)		840 x 980 x 970	816 x 906 x 965	668.7 x 800.6 x 891.3
Weight without rotor		480 kg	355 kg	230 kg
Power requirement		3.0 kVA	5.0 kVA	3.0 KW
Power input (V, Hz)		210~240V, 60 Hz (110V, 50 Hz optional)		210~240 V, 50/60 Hz (110V optional)
Cat. No.		CP-R12	CP-R6	CP-wR

* Registered as medical device at MFDS¹⁾

¹⁾ MFDS : Ministry of Food and Drug Safety (KOREA)

Swing-out Rotor for Component R12

WS2400-6

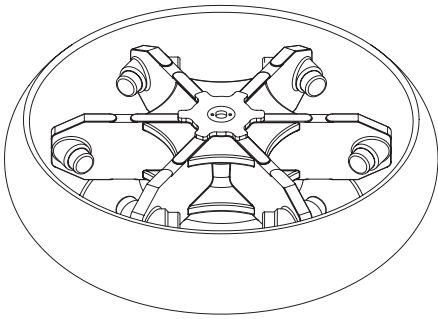

∠90°
Max. RPM : 4,800 rpm
Dim. W x D x H : 494 x 435.6 x 125 mm (w/o windshield)
Incl. a windshield and a lid

Bucket/Adaptor for WS2400-6

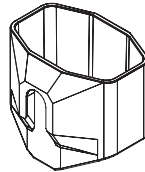

Blood Bag Bucket
B2400

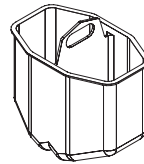

Adaptor
TRB500-2

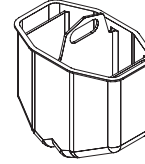

Adaptor
TRB450-2

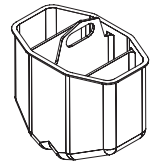

Adaptor
TRB250-2

Bucket and Tube Racks of WS2400-6

Bucket	Required Adaptor	Tube Capacity	Tube per Adaptor / Rotor	Max. height for tube fit (mm)	Max. RPM (rpm) Max. RCF (xg)
 Radius : 290 mm Bucket bore (ø x L, mm) : 176.9 x 150.8 Max. height for tube fit: 209.2 mm	TRB500-2 	500 mL	2 / 12	209.2	4,800 7,470
	TRB450-2 	450 mL	2 / 12		
	TRB250-2 	250 mL	2 / 12		

* Radius : From the center of the rotor to the inner end of tube carrier.

Large Capacity Centrifuges

Component R12 / Component R6 / Component wR

Swing-out Rotor for Component R6

WS1000-6

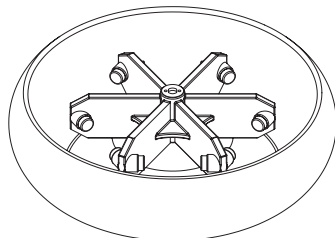

∠90°

Max. RPM : 5,000 rpm

Dim. W x D x H : 384 x 340 x 99 mm (w/o windshield)

Incl. a windshield and a lid

Bucket/Adaptor for WS1000-6

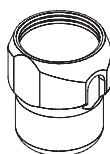

Bucket
B1000S

Capacity : 1,000 mL
* Cap Available (optional)

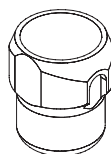

Bucket
B1000

Capacity : 1,000 mL





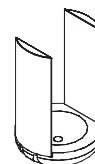

Cap
BL1000

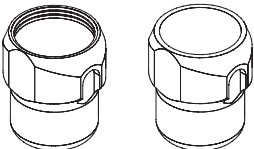
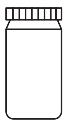

Adaptor
TRB450

Bucket and Tube Racks of WS1000-6

Bucket	Required Adaptor	Tube Capacity Bottom Type	Tube per Adaptor / Rotor	Bore (Ø x L, mm)	Max. height for tube fit (mm)	Max. RPM (rpm) Max. RCF (xg)
B1000S / B1000 	-	 1,000 Flat	1 / 6	98.5 X 143	193.7	5,000 7,261
BL1000  Radius : 259.8 mm Bucket bore (Ø x L, mm) : 98.5 x 143 Max. height for tube fit : 170 mm (w/ cap), 193.7 mm (w/o cap)	TRB450 	 480 mL -	1 / 6	65.5 x 135	178.7	5,000 6,842

* Radius : From the center of the rotor to the inner end of tube carrier.

Swing-out Rotor for Component wR

WS750-6

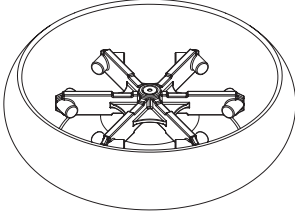

∠90°

Max. RPM : 4,500 rpm

Size (ø x H) : Ø262 x 262 mm
(w/o windshield)

Incl. a windshield and a lid

Bucket/Adaptor for WS750-6



Round Bucket
B750S

Capacity : 750 mL
* Cap Available (optional)



Round Bucket
B750

Capacity : 750 mL

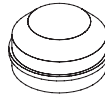

Cap
BL750

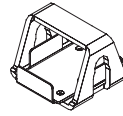

MicroTiter Plate Rack
TM96 (750-4)

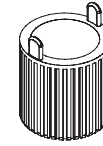

Adaptor
TR500 (750)



Adaptor
TR500c (750)

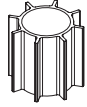

Adaptor
TR250 (750)

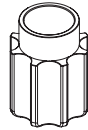

Adaptor
TR250c (750)

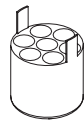

Adaptor
TR50-7

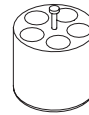

Adaptor
TR50c-5

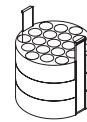

Adaptor
TR15-19

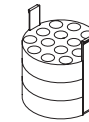

Adaptor
TR15c-14

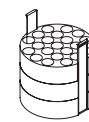



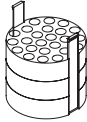





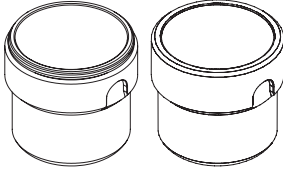
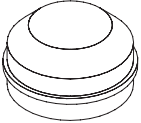















Adaptor
TR10-21

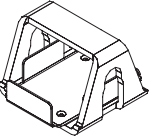

Adaptor
TR5-24

Bucket and Tube Racks of WS750-6

Bucket	Required Adaptor	Tube Capacity Bottom Type	Tube per Adaptor / Rotor	Bore (Ø x L, mm)	Max. height for tube fit (mm)	Max. RPM (rpm) Max. RCF (xg)
B750S / B750  BL750  Radius : 225 mm Bucket bore (ø x L,mm) : 99 x 103 Max. height for tube fit : 142 mm (w/ cap), 162.9 mm (w/o cap) Incl. a windshield and a lid	-	 750 mL Flat	1 / 6	99 x 103	150	4,500 5,096
	TR500(750) 	 500 mL Flat	1 / 6	75.5 x 98.7	125.7	4,500 5,042
	TR500c(750) 	 500 mL conical Conical	1 / 6	99 x 58	129	4,500 5,096
	TR250(750) 	 250 mL Flat	1 / 6	62.3 x 87	125	4,500 5,003
	TR250c(750) 	 250 mL conical Conical	1 / 6	60.5 x 124.4	125.5	4,500 5,015
	TR50-7 	 50 mL Round	7 / 42	29.2 x 97	125	4,500 5,003
	TR50c-5 	 50 mL conical Conical	5 / 30	29 x 91	129	4,500 5,096
	TR15-19 	 15 mL Round	19 / 114	17.2 x 87	125	4,500 5,003
	TR15c-14 	 15 mL conical Conical	14 / 84	17 x 89	127	4,500 5,049
	TR10-21 	 10 mL Round	21 / 126	16 x 87	125	4,500 5,003
TR5-24 	 3 mL / 5 mL Round	24 / 144	13.2 x 60 (3 mL) 13.2 x 87 (5 mL)	125	4,500 5,003	
TM96(750-6) Radius : 191.9 mm MTP holder size (w x d x L, mm) : 88 x 128.5 x 42 Max. height for tube fit : 88 x 128.5 x 42 mm		 MTP	1 / 6	88 x 128.5 x 42		4,500 4,345

* Radius : From the center of the rotor to the inner end of tube carrier.